



Pump • Fire Fighting Units • Booster Set

SDS / SDS-V DOUBLE SUCTION PUMPS



SDS / SDS-V Rev.05 03.2024



Handled Liquids

Clean or slightly contaminated low viscosity liquids without solid & fibrous particles.

Technical Data

Discharge Flange _____ DN 65.....DN 600 mm

Capacity _____ up to 6000 m³/h

Head _____ up to 180 m

Speed _____ up to 2900 rpm

Design Temperature _____ -10 °C' to +110 °C*

Casing Pressure (Pmax) _____ 16 bar - 25 bar*

(Pmax: Suction Pressure + Shut off Head)

(*) The Material of pumps differ according to the type of pumped liquid, operating temperature and pressure. Contact for detailed information.

Design Features

- Horizontal or vertical manufacturing option. Axial split case, single stage, double suction centrifugal pumps.
- Suction and discharge flanges are on the same axis on the bottom casing. Split case design permits easy disassembly of the rotor group for maintenance or repair without distorting pump alignment and suction / discharge piping.
- Suction and Discharge Flanges are conform to EN 1092-2/PN 16 or PN25.

Pump Designation

Pump Type _____

Vertical Installation _____

Discharge Nozzle (DN-mm) _____

Nominal Impeller Diameter (mm) _____

SDS - V 200 - 500

- All impellers are balanced dynamically or statically according to ISO 1940 class 6.3.
- Impeller is of double suction design. This feature increases pump suction performance in addition with providing the balance of hydraulic axial forces resulting higher bearing lifes and higher reliability.
- In standard construction, the direction of rotation is clockwise when it is looked from drive end. In this case, suction flange is on right and discharge flange is on left. Upon request the direction of rotation can be reversed. This time the position of the suction and discharge flanges are also reversed.
- Grease lubricated ball bearings are used in horizontal installation. In case of vertical installation, pumping liquid lubricated journal bearings on top and grease lubricated ball bearings on bottom are used.

Shaft Sealing

- Depending on request or requirement, pumps with soft packing or single, double and cartridge type mechanical seals can be supplied.

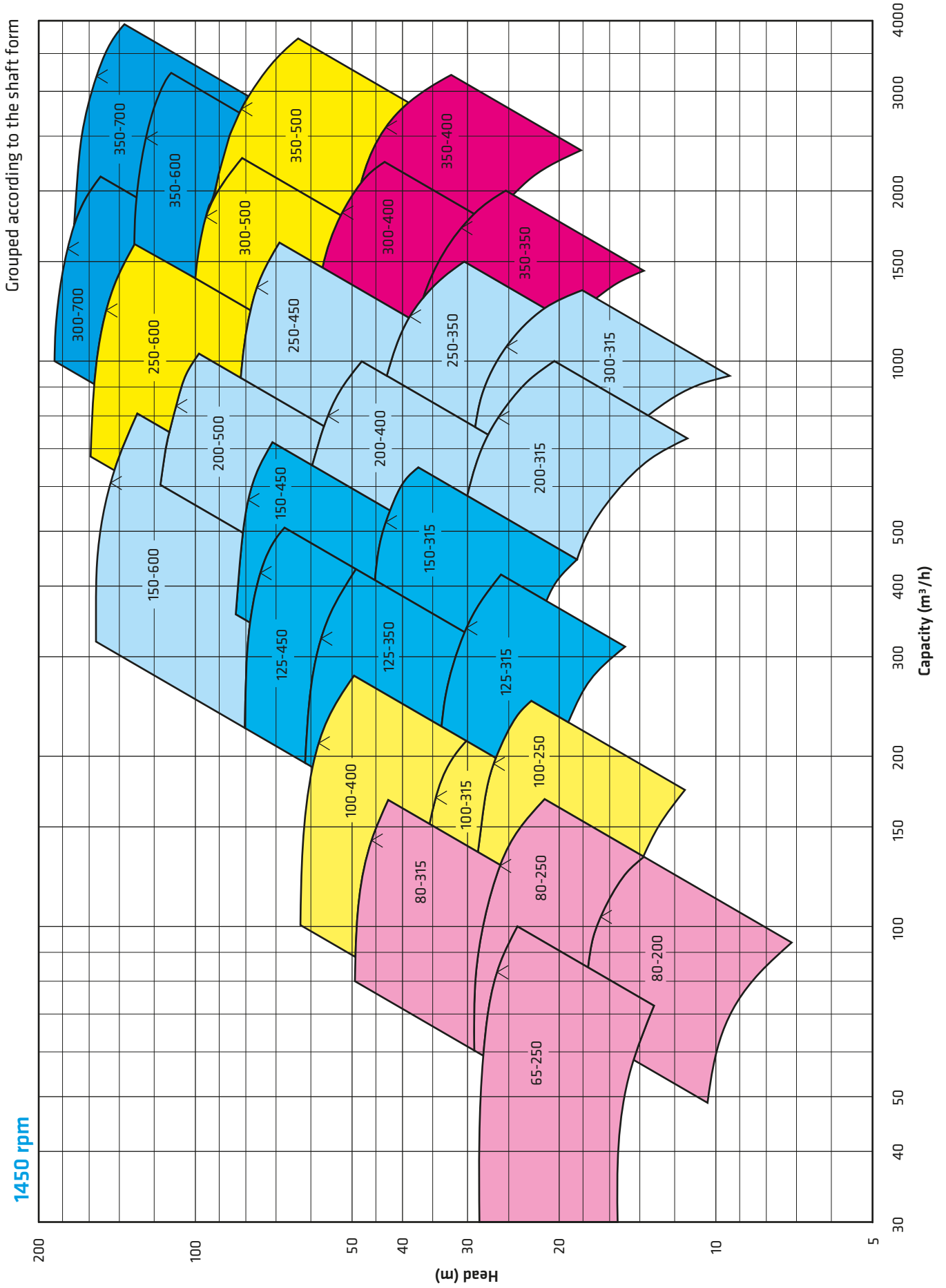

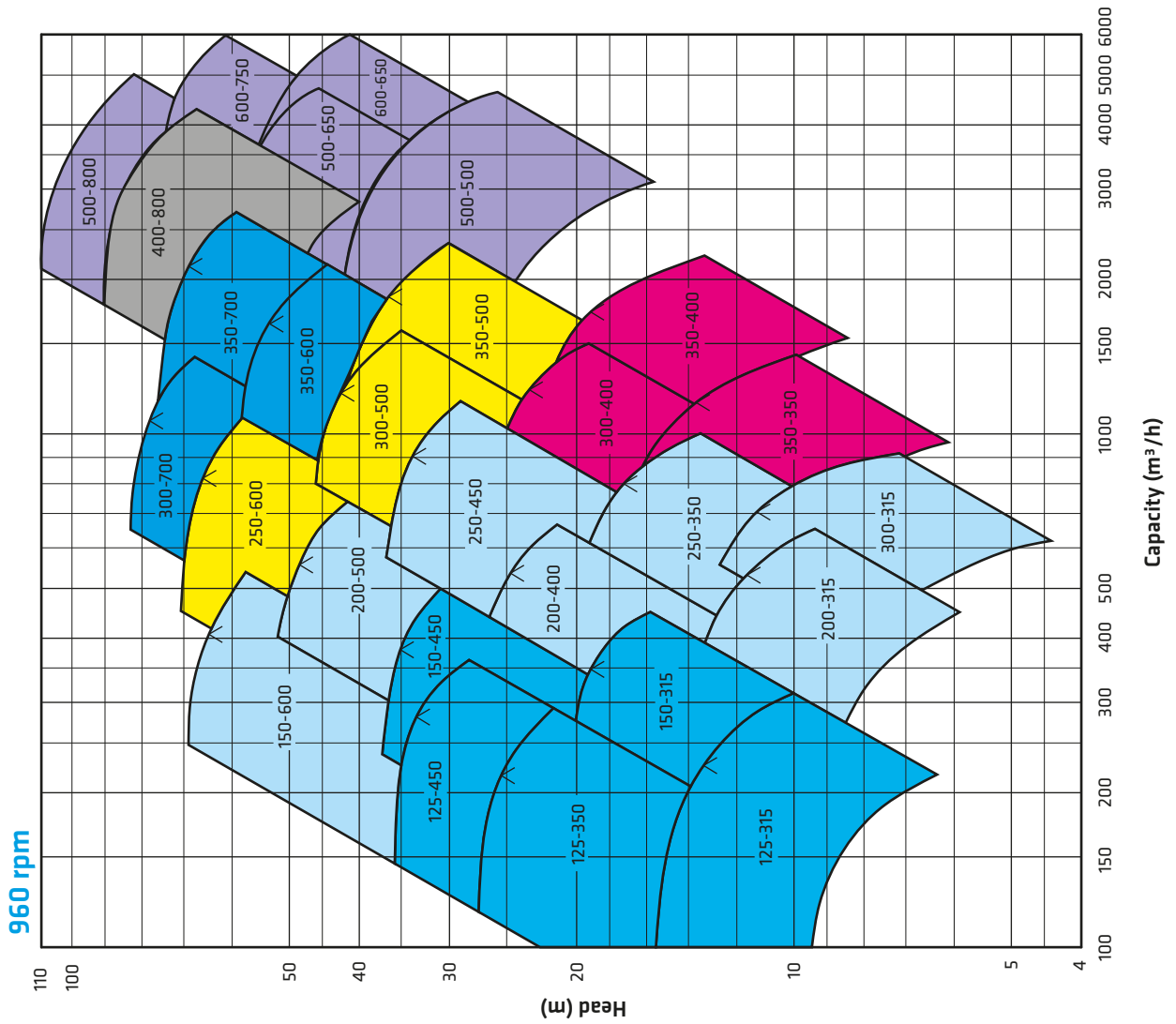
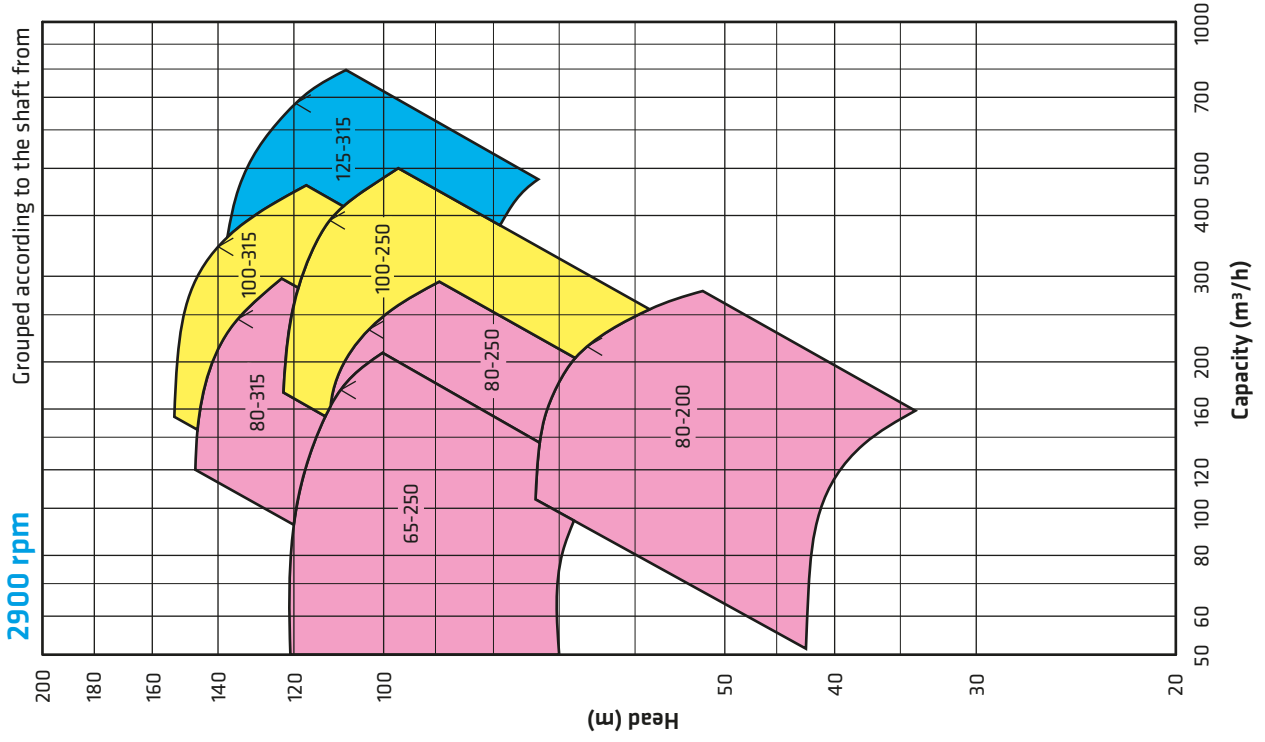

* Mechanical Seal Application

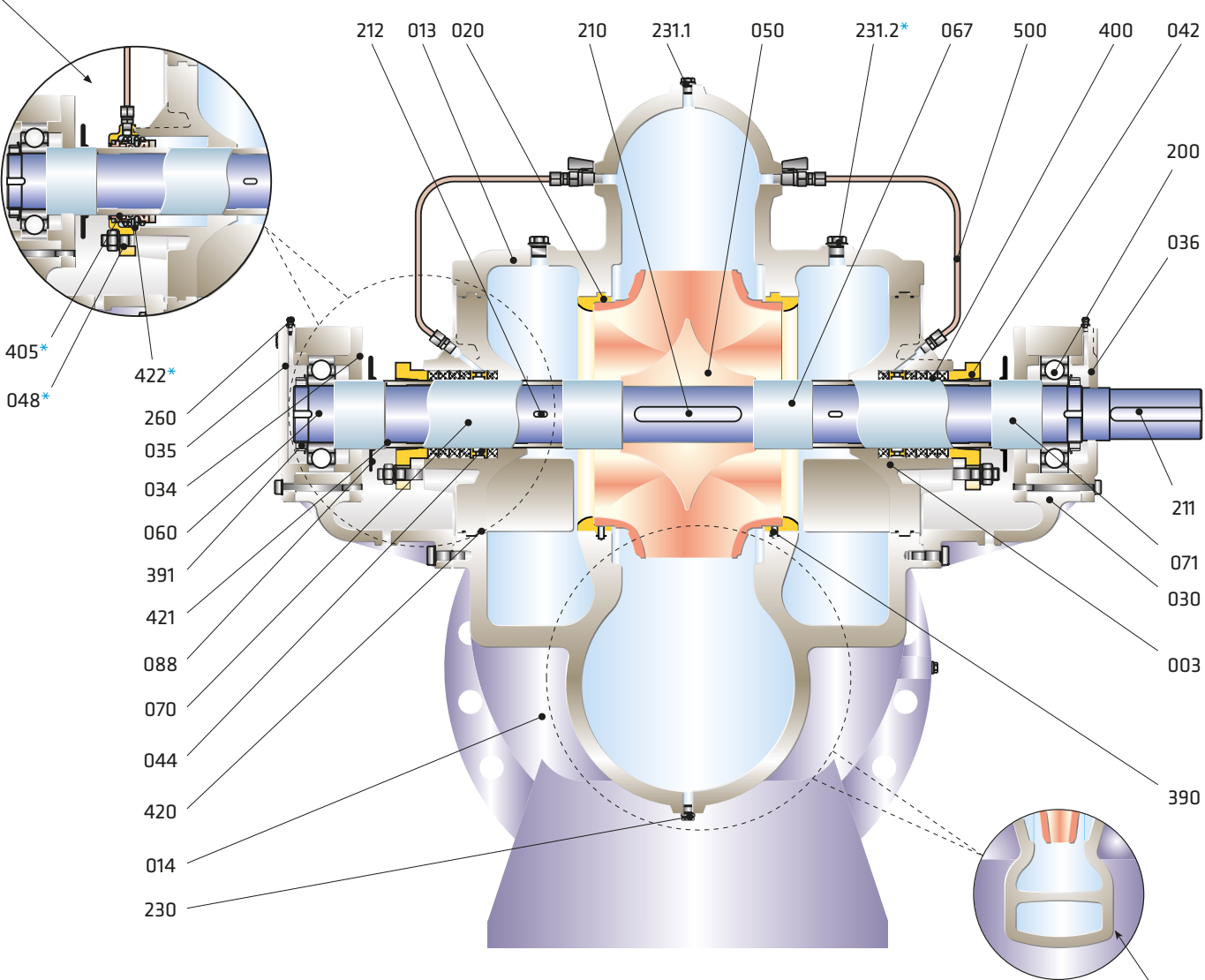

Part List

003	Stuffing Box	200	Ball Bearing
013	Volute Casing (top half)	210	Impeller Key
014	Volute Casing (bottom half)	211	Coupling Key
020	Wear Ring	212	Spacer Sleeve Key
030	Bearing Bracket	230	Drain Plug
034	Bearing Cover (inboard)	231.1	Air Plug
035	Bearing Cover (outboard)	231.2*	Air Plug
036	Bearing Cover (coupling)	260	Grease Nipple
042	Stuffing Box Gland	390	Pin
044	Lantern Ring	391	Shaft Nut & Lock Washer
048*	Mechanical Seal Cover	400	Stuffing Box Packing
050	Impeller	405*	Mechanical Seal
060	Pump Shaft	420	O-Ring
067	Spacer Sleeve	421	O-Ring
070	Shaft Protecting Sleeve	422*	O-Ring
071	Shaft Protecting Sleeve	500	Flushing Pipe
088	Thrower		

(*) Optional

** Double Volute Application

** Double Volute Design is Applied to:

- SDS 200 - 500
- 250 - 600
- 300 - 500
- 300 - 700
- 350 - 500
- 350 - 700

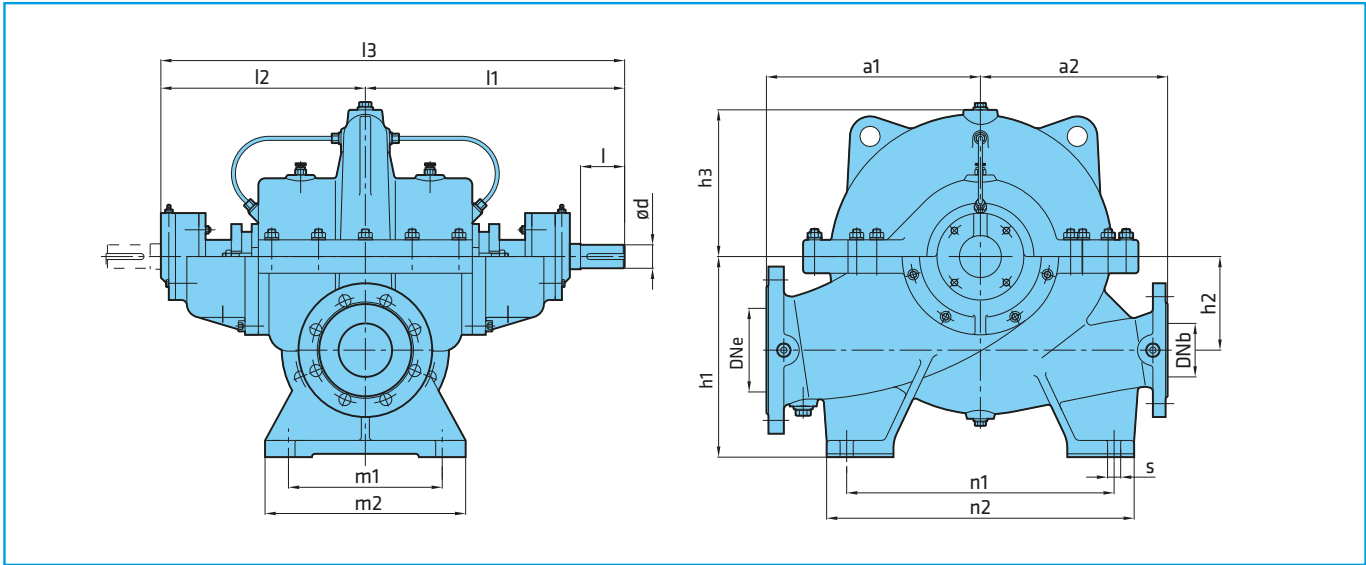

Pump Type	Dimensions (mm)																			Weight (kg)
	PNe	PNb	DNe	DNb	ød	l	l1	l2	l3	a1	a2	h1	h2	h3	n1	n2	m1	m2	s	
65-250	16	16	100	65	35	75	400	305	705	320	280	300	140	200	400	460	230	300	20	165
80-200	16	16	125	80	35	75	400	305	705	320	280	300	140	200	400	460	230	300	20	165
80-250	16	16	125	80	35	75	400	305	705	320	280	300	140	200	400	460	230	300	20	175
80-315	16	16	125	80	35	75	400	305	705	360	300	300	140	260	400	460	230	300	20	197
100-250	16	16	150	100	42	90	450	350	800	360	310	355	170	235	400	480	280	340	20	220
100-315	16	16	150	100	42	90	450	350	800	360	310	355	170	250	400	480	280	340	20	230
100-400	16	16	150	100	42	90	450	350	800	420	370	355	170	300	460	540	280	340	20	290
125-315	16	16	200	125	55	120	555	420	975	420	370	400	200	280	460	540	320	380	22	330
125-350	16	16	200	125	55	120	555	420	975	470	450	400	200	300	540	660	320	380	22	380
125-450	16	16	200	125	55	120	555	420	975	500	450	400	200	350	540	640	320	380	22	410
150-315	16	16	200	150	55	120	555	420	975	470	400	400	200	315	540	640	320	380	22	395
150-450	16	16	200	150	55	120	555	420	975	500	450	400	200	365	540	640	320	380	22	430
150-600	25	25	250	150	65	130	645	500	1145	550	500	560	300	445	540	640	320	420	22	800
200-315	16	16	250	150	65	130	645	500	1145	500	450	560	240	315	540	640	320	420	22	395
200-400	16	16	250	200	65	130	645	500	1145	500	450	500	240	360	540	640	320	420	22	430
200-500	16	16	250	200	65	130	645	500	1145	550	500	560	300	380	620	720	320	420	22	700
250-350	16	16	300	250	65	130	645	500	1145	600	500	600	300	390	620	720	320	420	22	682
250-450	16	16	300	250	65	130	645	500	1145	600	500	600	300	415	620	720	320	420	22	780
250-600	25	25	300	250	80	170	720	540	1260	650	550	600	300	430	620	710	415	485	26	1190
300-315	16	16	350	300	65	130	645	500	1145	600	500	630	300	400	620	700	320	420	22	700
300-400	16	16	400	300	75	140	770	615	1385	700	550	710	350	400	720	800	420	520	26	1125
300-500	16	16	400	300	75	170	755	585	1340	700	750	710	350	425	700	800	420	520	26	1500
300-700	25	25	400	300	100	180	865	675	1540	750	800	710	350	450	700	800	420	520	26	1650
350-350	16	16	400	350	75	140	770	615	1385	700	550	670	350	450	720	800	420	520	26	1100
350-400	16	16	500	350	75	140	770	615	1385	800	600	800	380	500	800	960	500	600	26	1400
350-500	16	16	500	350	80	170	755	585	1340	800	600	800	400	435	740	900	500	600	26	1435
350-600	25	25	500	350	100	180	900	715	1615	700	700	730	470	503	750	900	520	600	28	1900
350-700	25	25	500	350	100	180	865	675	1540	850	750	850	450	525	720	880	500	600	28	2000
400-800	16	16	600	400	105	220	1035	810	1845	900	900	880	400	565	950	1120	630	740	26	3400
500-500	16	16	600	500																
500-650	16	16	600	500																
500-800	16	16	600	500																
600-650	16	16	700	600																
600-750	16	16	700	600																

Contact for detailed information

Note: All rights reserved due to dimension change.

PART LIST	10	30	35	20	60	6L	70	7L	8M	7D	7S	8N	80	4C	4A	40	80	8T	60	7L	7E	7D	
	0.6025	0.7040	0.7043	1.0619	1.4308	1.4309	1.4408	1.4409	1.4500	1.4517	1.4469	1.4317	1.4008	2.1050.01	2.0975.01	2.1096.01	1.4021	1.4021+QT	1.4301	1.4404	1.4460	1.4462	
Volute Casing(**)	●	○	○	○	○	○	○	○	○	○	○	○	○	○	○	○							
Impeller	●	○	○	○	○	○	○	○	○	○	○	○	○	○	○	○						○	
Shaft																	●	○	○	○			○
Bearing Housing	●	○	○	○	○	○	○	○															
Wear Ring (Casing)	●	○	○	○	○	○	○	○	○	○	○	○	○	○	○	○							
Shaft Protecting Sleeve																	●	○	○	○			○

Depending on customer requirement or request different types and brands of mechanical seals are applicable.

(*) 0.7040 material is used in standard production for types which has PN 25 casing pressure class

● Standard manufacturing
○ Optional

Material Equivalents

Description	DIN / EN		AISI / SAE / ASTM
Cast Iron	0.6025	EN-GJL-250 (GG25)	A48 Class 40B
Nodular Cast Iron	0.7040	EN-GJS-400-15 (GGG40)	A536 60-40-18
Nodular Cast Iron	0.7043	EN-GJS-400-18-LT (GGG40.3)	A536 60-40-18
Cast Steel	1.0619	GP240GHGS-C25	A216 WCB
Chrome Nickel Cast Steel	1.4308	GX5CrNi19-10	A351 CF8
Chrome Nickel Cast Steel (low carbon)	1.4309	GX2CrNi19-11	A351 CF3
Chrome Nickel Molybdenum Cast Steel	1.4408	GX5CrNiMo19-11-2	A351 CF8M
Chrome Nickel Molybdenum Cast Steel (low carbon)	1.4409	GX2CrNiMo19-11-2	A351 CF3M
Austenitic Cast Steel	1.4500	GX7NiCrMoCuNb25-20	A351 CN7M
Austenitic - Ferritic Cast Steel (duplex)	1.4517	GX2CrNiMoCuN25-6-3-3	A890 CD4MCuN
Austenitic - Ferritic Cast Steel (super duplex)	1.4469	GX2CrNiMoN26-7-4	A890 CE3MN
Martenzitic Stainless Cast Steel	1.4317	GX4CrNi13-4	A352 CA6NM
Martenzitic Stainless Cast Steel	1.4008	GX7CrNiMo12-1	A217 CA15
Cast Bronze (tin alloy)	2.1050.01	G-CuSn10	B427 C90700
Cast Bronze (nickel alloy)	2.0975.01	G-CuAl10Ni	B148 C95500
Cast Bronze (Leaded)	2.1096.01	G-CuSn5ZnPb	B584 C83600
Chrome Steel	1.4021	X20Cr13	A276 Type 420
Chrome Steel(heat treated)	1.4021	X20Cr13	A276 Type 420+QT
Chrome Nickel Steel	1.4301	X5CrNi18-10	A276 Type 304
Chrome Nickel Steel (low carbon)	1.4404	X2CrNiMo17-12-2	A276 Type 316L
Duplex (austenitic-ferritic) Steel	1.4460	X3CrNiMoN27-5-2	AISI 329
Duplex (austenitic-ferritic) Steel	1.4462	X2CrNiMoN22-5-3	UNS S32205

Flange Dimensions

EN 1092 - 2	DNe/DNb	Suction & Discharge (PN 16)				Suction & Discharge (PN 25)			
		Df	k	s	n	Df	k	s	n
65	185	145	18	4	185	145	18	8	
80	200	160	18	8	200	160	18	8	
100	220	180	18	8	235	190	22	8	
125	250	210	18	8	270	220	26	8	
150	285	240	22	8	300	250	26	8	
200	340	295	22	12	360	310	26	12	
250	405	355	26	12	425	370	30	12	
300	460	410	26	12	485	430	30	16	
350	520	470	26	16	555	490	33	16	
400	580	525	30	16	620	550	36	16	
500	715	650	33	20	730	660	36	20	
600	840	770	36	20	845	770	39	20	
700	910	840	36	24	960	875	42	24	

" n " number of holes

